



Computer Talent Search

A project of the Institute of IT Professionals South Africa

Ph: 021-448 7864 • Fax: 021-447 8410 • PO Box 13013, MOWBRAY, 7705 • info@olympiad.org.za • www.olympiad.org.za

INTERMEDIATE

Grades 8 and 9

Not to be used before 7 March

If you are NOT in grade 8 or 9, please report that you have the wrong paper.
Only when the teacher says “START”, may you begin.

1. Write your personal details and your answers on the answer sheet provided.
2. You will have 45 minutes to complete the 15 tasks.
3. You may answer the questions in any order, but it is important to place the answer in the correct line on the answer sheet.
4. Leave the tasks you find difficult for last.

The mark allocation is as follows.

A section: +6 marks for every correct answer.

B section: +7 marks for every correct answer.

C section: +7 marks for every correct answer.

If you do not answer a question or answer incorrectly, you get 0 (zero) for that task.

The maximum mark is 100.

Wait for the teacher to say “START”.

Supported by



**science
& technology**

Department:
Science and Technology
REPUBLIC OF SOUTH AFRICA

Sponsored by



Standard Bank

A1 Bracelet

ID362 / JA1 / IA1

Emily has broken her favourite bracelet. The broken bracelet now looks like this:

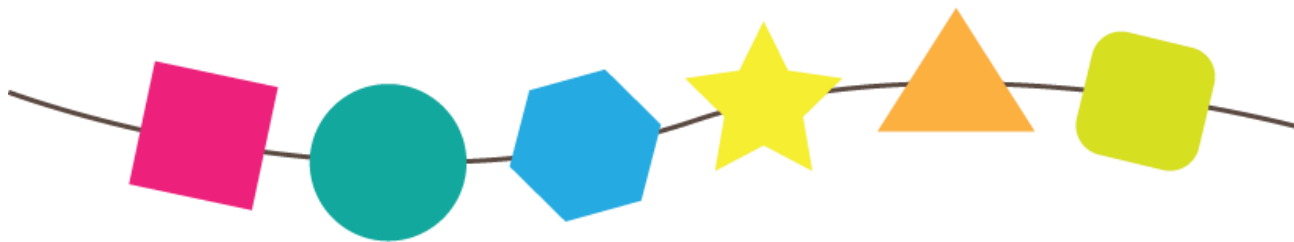

Question:

Which of the following four bracelets shows what the bracelet looked like when it was whole? Write down the letter of your answer in the appropriate block on the answer sheet.

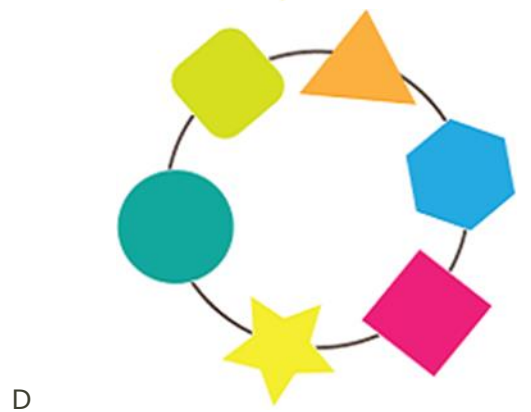
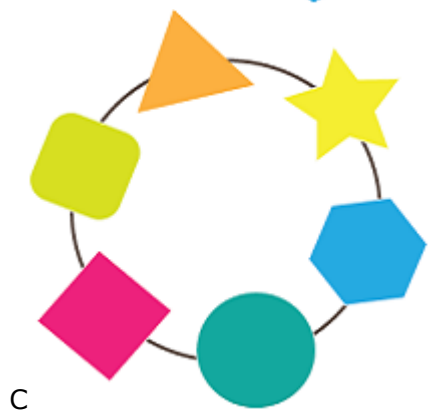
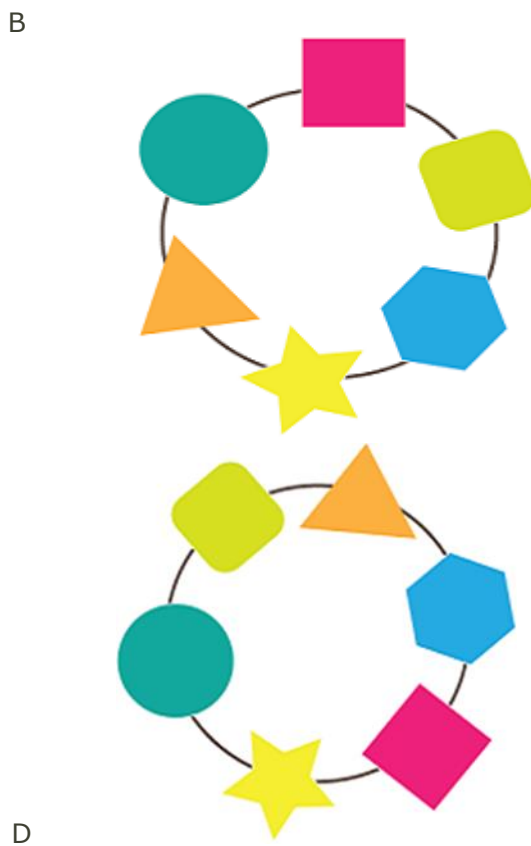
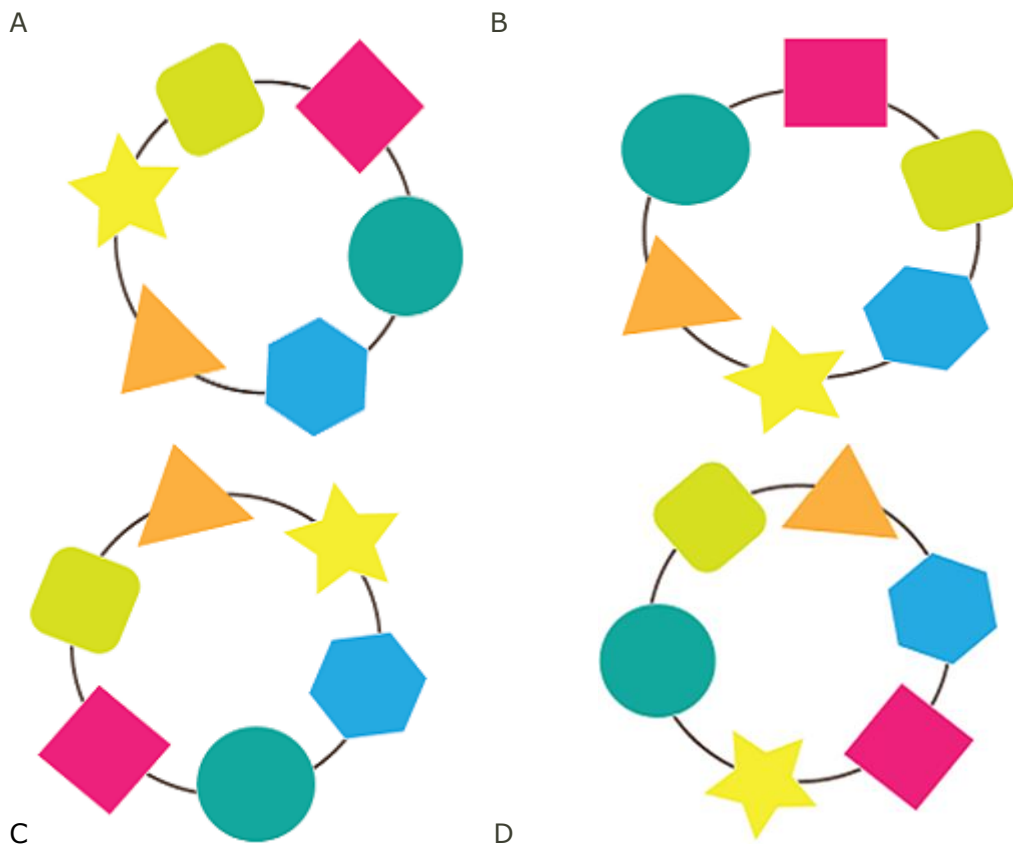





A2 Dream Dress

ID367 / JA3 / IA2

Kate wants to buy her dream dress. It must

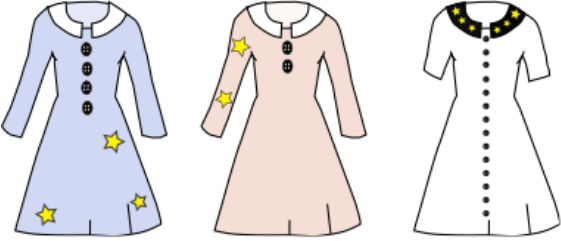
- have short sleeves, and
- have more than 3 buttons, and
- have stars on its sleeves.

Four shops sell only the dresses shown.

<h3>BeaverYorker</h3> 	<h3>BeaverNova</h3> 
<h3>B&B</h3> 	<h3>TomTeaver</h3> 

Question:

Which one of these shops sells Kate's dream dress? Write down the name do the shop in the appropriate block on your answer sheet.

BeaverYorker
BeaverNova
B&B
TomTeaver

A3 Geocaching

ID369 / JB3 / IA3

Two friends, Anna and Bob, are searching for treasure.

They have a smartphone app that shows them the direction to the treasures they are looking for.

The two boxes on the map show where the treasures are.



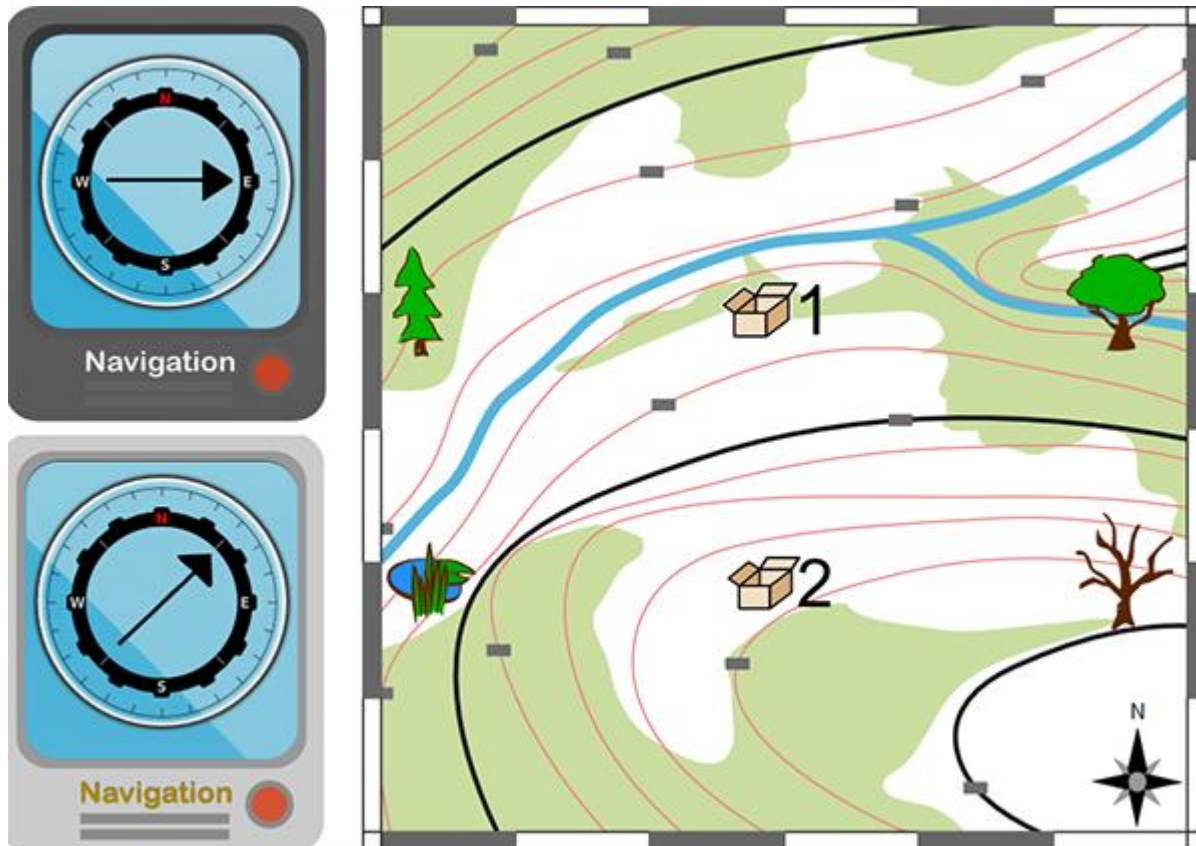

Anna is searching for box 1. Bob is looking for box 2.



Anna and Bob are standing in the same place. The picture shows the map and a screenshot of the smartphones.

Question:

Where are Anna and Bob standing? Write down the letter of the correct answer in the appropriate block on your answer sheet.

- A. 
- B. 
- C. 
- D. 

A4 Super Power Family

ID329 JB4 / IA4 / SA3 / EB1

- All members of this family have abilities.
- A daughter inherits all her abilities from her mother.
- A son inherits all his abilities from his father.
- Each family member also has one extra ability.

The diagram below shows the relationships between the members. It also shows the extra ability for each member.

Examples:

- Mother Jennifer has inherited the ability to sing from Grandmother Maria, and she also has the ability to program.
- Lisa inherits two abilities from her mother and also has the ability of writing. This means she can write, program and sing.

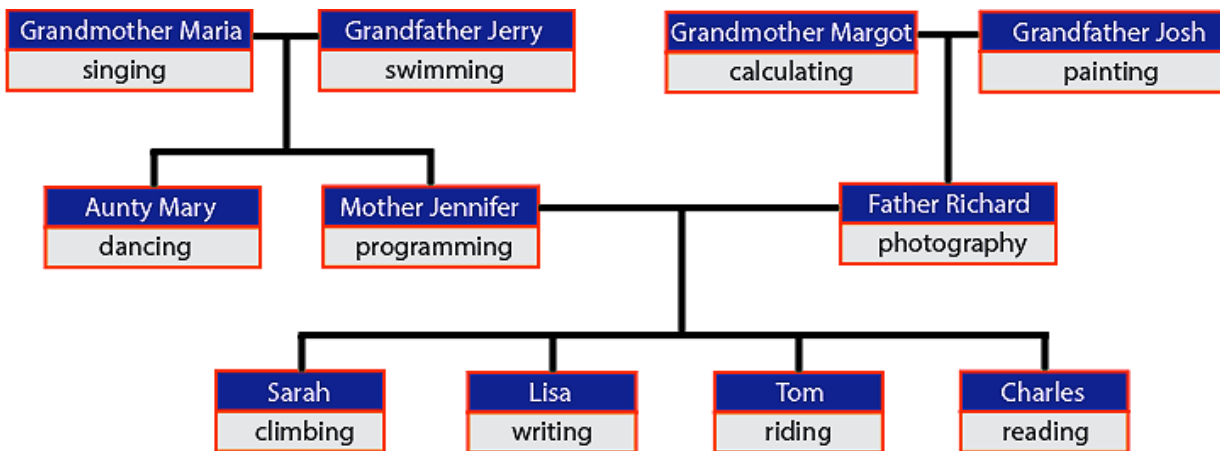

Question:

Look at the diagram above. Which one of the following statements is true? Write down the letter of the answer in the appropriate block on your answer sheet.

- A. Sarah has abilities in reading, programming and singing.
- B. Aunt Mary has abilities in dancing and swimming.
- C. Tom inherits from Grandmother Margot the ability to calculate.
- D. Tom's abilities are riding, painting and photography.

A5 Animation

ID371 / JB2 / IA5

Taro is planning an animation of a face that is made from a sequence of pictures.

To make the animation run smoothly, only one feature of the face should change from one picture to the next.

Unfortunately, the pictures got mixed up. Now Taro must find the correct order again. Luckily, he knows which picture is last.

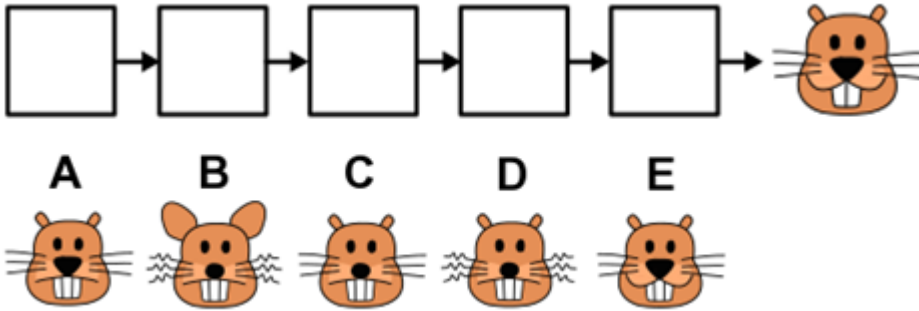

Question:

Which of the answers A, B, C or D are in the correct order? Write down the letter of the correct answer in the appropriate block on your answer sheet.

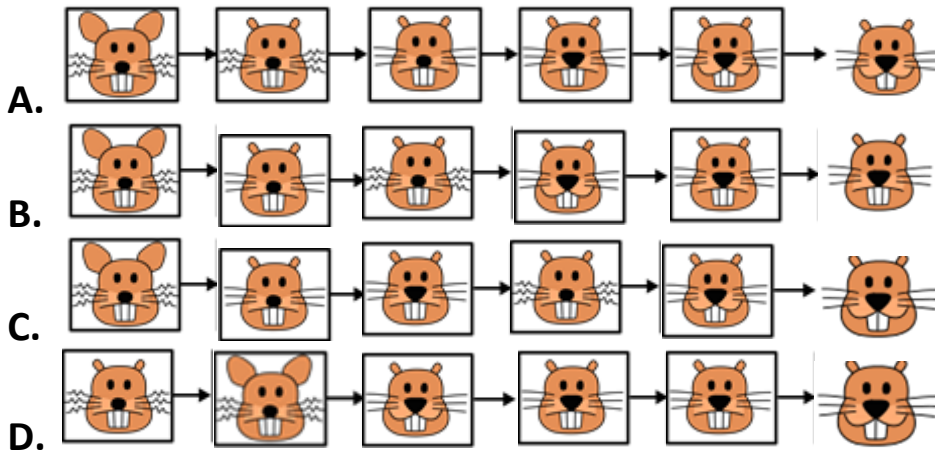

B1 Drawing Stars

ID342 / IB1 / SA4 / EA3

Stella loves to draw stars. She has devised a system for labelling her stars according to their shape. She uses two numbers:

- A number of points for the star.
- A number indicating if a line from a dot is drawn to the nearest point (the number is 1), the second closest point (the number is 2), etc.

Here are four examples of Stella's labelling system:

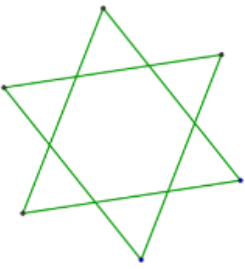
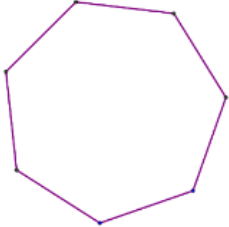
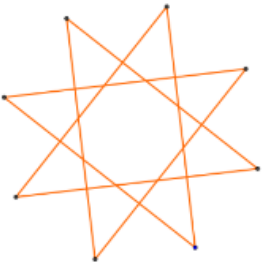
			
5:2	6:2	7:1	8:3

Question:

How would Stella label the following star? Write down the letter of the correct answer in the appropriate block on your answer sheet.

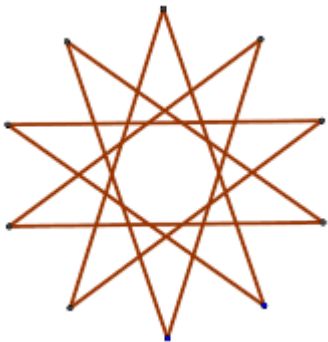

- A. 9:3
- B. 9:4
- C. 10:4
- D. 10:5

B2 Drawing Patterns

ID322 / JC2 / IB2

Target Pattern

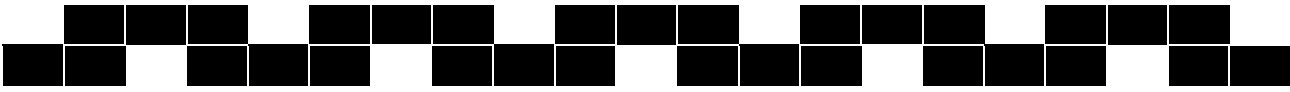

Start



Your job is to select the sequence of instructions that draws the target pattern shown above.

Write the letter of your answer in the appropriate block on your answer sheet.

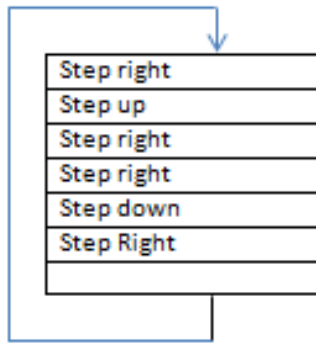

A. Repeat seven times

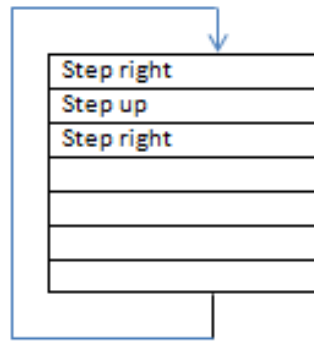

B. Repeat twelve times

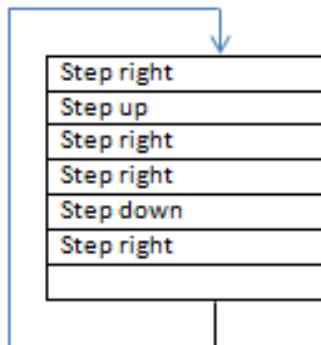

C. Repeat six times

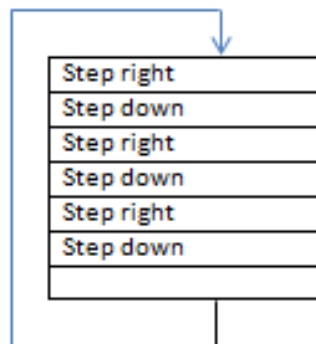

D. Repeat six times

B3 You Won't Find It

ID374 / IB3 / SA2 / EA2

Alex and Betty send each other messages using the following sequence of transformations on every word.

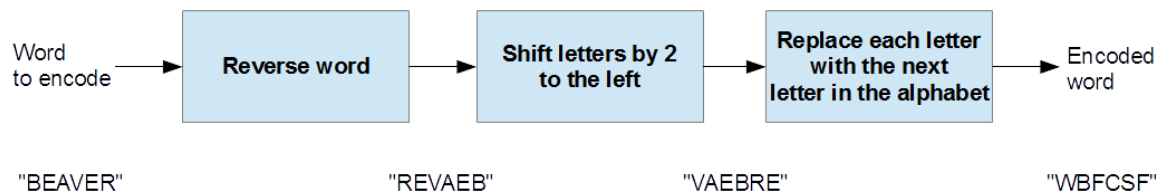

For example, the word "BEAVER" is transformed to "WBFCSF".

Betty receives the encoded message "PMGEP" from Alex.

Question:

What did Alex want to say? Write down the word in the appropriate block on your answer sheet.

LODGE
FLOOD
RIVER
KNOCK

B4 Throw the dice

ID376 / JC3 / IB4 / SB1

After school the young beavers are used to playing together.

To avoid quarrels about where to play, they throw a normal six sided die.

The decision is found according to this rule:

1	IF	The first throw is greater than the second throw
2	THEN	We go to play in the woods
3	ELSE	
4	IF	The third throw is less than the first throw
5	THEN	We go to play at the river
6	ELSE	We go to play on the sports field

Question:

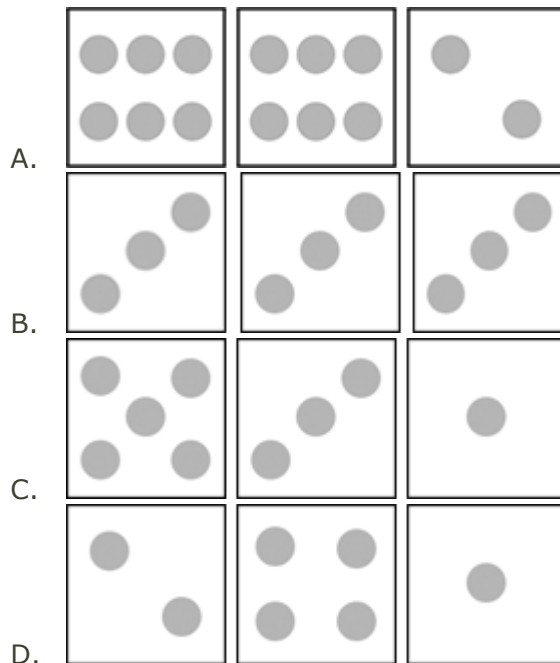

Which sequence of throws will send the young beavers to the sports field? Write down the letter of the answer in the appropriate block on your answer sheet.



B5 Cross Country

ID373 / JC4 / IB5

Three very fast beavers will compete in a cross-country run.

Mr. Brown will overtake one beaver when running uphill.	
Mrs. Pink will overtake one beaver when running downhill.	
Mrs. Green will overtake one beaver when running across rocks.	

The course is shown in the picture: uphill, followed by some rocks, downhill and then some more rocks.

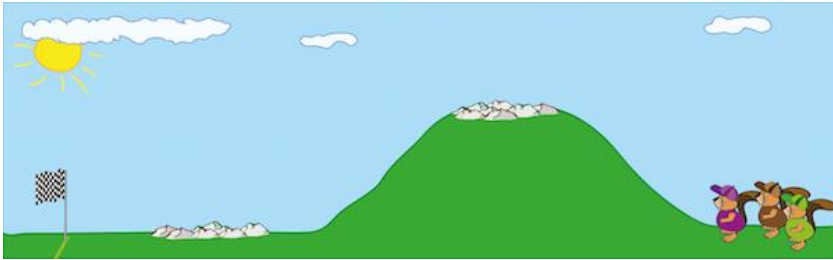

Mrs. Pink starts in the first position, followed by Mr. Brown and then Mrs. Green.

Question:

In which order will the beavers finish the race? Write down the letter of the correct answer in the appropriate block on your answer sheet.

- A. Mrs Pink, Mr Brown, Mrs Green
- B. Mrs Green, Mrs Pink, Mr Brown
- C. Mr Brown, Mrs Green, Mrs Pink
- D. Mr Brown, Mrs Pink, Mrs Green

C1 Animal Competition

ID370 / IC1



The beavers and dogs had a competition. In total nine animals took part.

The nine participants had the following scores: 1, 2, 2, 3, 4, 5, 5, 6, 7.

No dog scored more than any beaver.

One dog tied with a beaver.

There were also two other dogs that tied with each other.

Question:

How many dogs took part in the competition?

Write the number in the appropriate block on your answer sheet.

C2 Fair share

ID308 / JC5 / IC2 / SB3

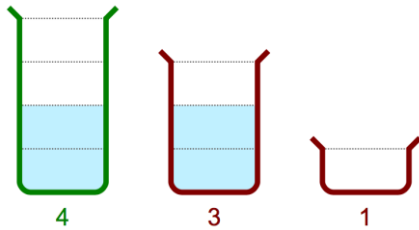

Hamid has a 4 litre beaker full of a hazardous chemical. Kazim has an empty 3 litre beaker and another empty 1 litre beaker.

Hamid and Kazim want to share the chemical between them equally and use a machine to do this safely.

The machine can pour one beaker in to another. It stops pouring when a beaker is completely emptied or filled, whichever happens first.

Question:

Find the sequence of pours that produces equal shares of the chemical for Hamid and Kazim. Pouring from the 4 litre beaker to the 3 litre beaker is shown as $4 \rightarrow 3$, etc.

Your sequence must use the minimum number of pours possible. Write down the letter of the correct pours in the appropriate block on your answer sheet.

- A. $4 \rightarrow 1$, $4 \rightarrow 3$, $1 \rightarrow 4$, $3 \rightarrow 1$, $1 \rightarrow 4$
- B. $4 \rightarrow 1$, $1 \rightarrow 3$, $4 \rightarrow 1$, $1 \rightarrow 3$
- C. $4 \rightarrow 1$, $4 \rightarrow 3$, $1 \rightarrow 4$,
- D. $4 \rightarrow 3$, $3 \rightarrow 1$, $1 \rightarrow 4$

C3 Beaver Lunch

ID381 / IC3 / SC3

Hm, what to take for lunch today?

The cafeteria gives instructions on how to choose a good lunch.

This is shown as a diagram:

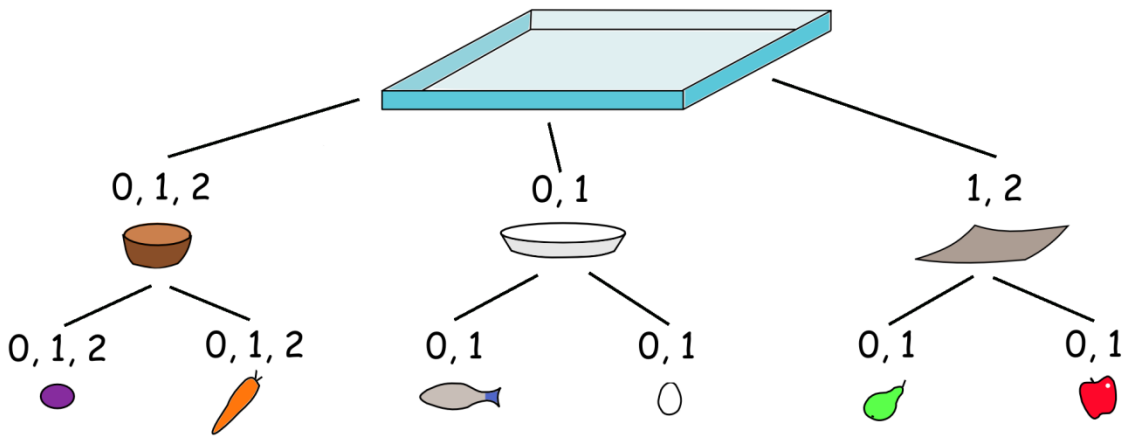

Below the tray you see different types of food containers.

The numbers above the containers indicate how many containers of this type can be added to a tray.

Each container can only have food items put in it that are shown below it.

The numbers above the food items indicate how many food items of this type can be added to the containers.

Question:

Which of the following lunches is **NOT** a proper lunch? Write down the letter of the correct solution in the appropriate block on your answer sheet.



A

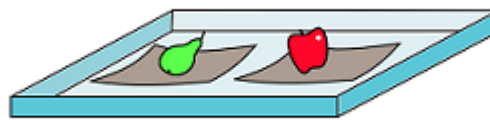

B

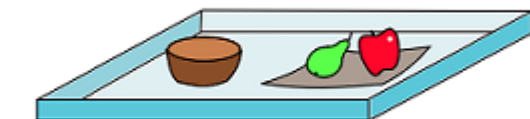

C



D

C4 Theatre

ID378 / IC4 / SB5

Three spotlights are used to light the theatre stage in the beavers' forest -- a red one, a green one and a blue one.

The colour of the stage depends on which of the three spotlights are turned on.

This table shows the possible combinations of colours.

Red light	Green light	Blue light	Stage colour
off	off	off	Black
off	off	on	Blue
off	on	off	Green
off	on	on	Cyan
on	off	off	Red
on	off	on	Magenta
on	on	off	Yellow
on	on	on	White

From the beginning of the show, the lights will be switched on and off in this pattern:

- The red light repeats the sequence: two minutes off, two minutes on.
- The green light repeats the sequence: one minute off, one minute on.
- The blue light repeats the sequence: four minutes on, four minutes off.

Question:

What will the colour of the stage be in the first 4 minutes of the show?

Write down the minute and the colour in the appropriate block on your answer sheet.

Eg. 1. Blue 2. White 3. Green 4. Cyan

You need all the answers correct to get marks. No part marks are allocated. You get 7 marks or 0.

C5 Chakhokhbili

ID377 / IC5

Sergo loves to cook. His favourite meal is Chakhokhbili.

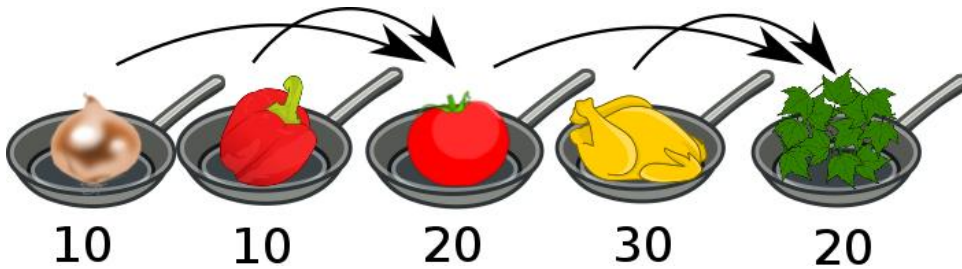

When cooking in the garden he uses a single gas burner. He performs the following actions after each other:

1	Cook an onion	10 minutes
2	Cook a bell pepper	10 minutes
3	Combine the cooked onion and cooked bell pepper, add a tomato and cook this together	20 minutes
4	Cook a chicken	30 minutes
5	Combine everything from steps 3 and 4, add some spices, and cook it all.	20 minutes

In total Sergo needs 90 minutes to prepare his Chakhokhbili on a single gas burner.

Question:

When Sergo cooks at home he has many gas burners available. He is able to use more burners so his meal is ready sooner.

Which of the following statements is **NOT** correct?

- A. Sergo can reduce the cooking time by 10 minutes when using 2 burners
- B. Sergo can reduce the cooking time by 30 minutes when using 2 burners
- C. Sergo can reduce the cooking time by 40 minutes when using 3 burners
- D. Sergo can reduce the cooking time by 50 minutes when using 4 burners

Write down the letter of the **NOT** correct statement in the appropriate block on your answer sheet.